

# OneWrap

## Semi-automatic Stretch-Wrapper

OneWrap is a flexible entry-level semi-automatic machine for wrapping palletised loads with stretch film. Starting from carriages with basic mechanical brake, up to the motorised Pre-Stretch version: OneWrap offers the right solution for most common pallet wrapping needs.

### KEY FEATURES

- **Safety First** – OneWrap incorporates several safety features as standard
- **No film waste** – With motorised Pre-Stretch system and independent tension control
- **Increased production capacity** – Thanks to customised settings
- **Strong construction** – 2.4T load capacity for less effort in maintenance and flat operating cost
- **Flexibility** – Machine easy to move with forklift (also after installation)
- **Easy to use** – Due to the simple control concept
- **Modular system** – Meeting your individual needs
- **Easy installation** – Delivered with column already mounted
- **CE Compliant** – Engineered and produced in Italy according to EU safety standards



### MACHINE DIMENSIONS

Version OneWrap – L – 15

Equipment, options and machine dimensions may differ depending on version.

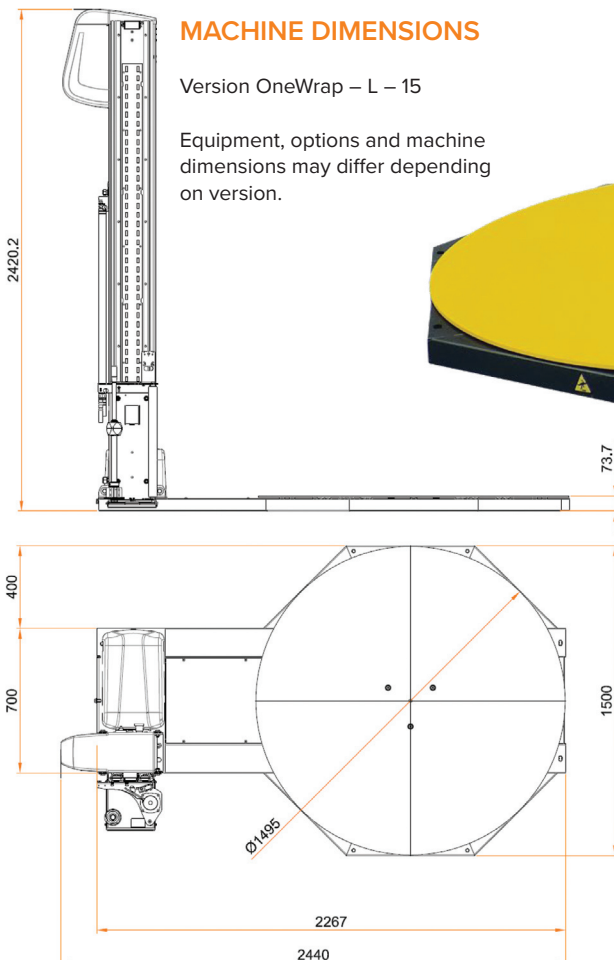

### CONTROL KEYBOARD



- User friendly icons and jog selector for quick parameter set-up
- 9 + 1 customisable programs
- Semi-automatic and manual working mode
- Individual speeds for up/down carriage movement
- Separated set-up for top and bottom reinforcement wraps
- Emergency push-button according to regulations

# OneWrap

## Semi-automatic Stretch-Wrapper

### TECHNICAL DATA

Carriage type	LP	SM	FM	M	EM
Description	Powered Pre-Stretch	Mechanical Pre-Stretch	Electro-Magnetic Brake	Mechanical Brake <i>incl. quick release</i>	Mechanical Brake
Pre-Stretch level (%)	240 / 200 / 150	90 / 60 / 30	–	–	–
Platform diameter (mm)	1500 std. / 1650 / 1800 / 2200 / 1500 HS ( <i>open turntable</i> )				1500
Max. pallet height (mm) <i>incl. overlap above pallet top edge</i>	2100 std. ( <i>Low</i> ) / 2400 ( <i>Medium</i> )				2100
Max. pallet size (mm)	800 x 1200 – 1550 x 1550 ( <i>depending on turntable diameter</i> )				800 x 1200
Max. working load (kg)	2400 std. ( <i>flat turntable</i> ) / 1200 HS ( <i>open turntable</i> )				2400
Power supply	220/240V 50/60Hz / 400V 50/60Hz ( <i>others on request</i> )				
Platform rotation speed	6 – 12rpm ( <i>adjustable</i> ) / 5 – 10rpm ( <i>adjustable</i> ) for HS platform				
Max. noise level	72.0 dB(A)				
Operating temperature	5 – 40°C				
Film roll details (max.)	width 500mm / ext. $\Phi$ 300mm / core $\Phi$ 76mm (fix) / weight 20kg / thickness up to 35 micron				

Features	LP	SM	FM	M	EM
Manual + 4 automatic modes	•	•	•	•	•
9 + 1 individual programs	•	•	•	•	•
Pre-Stretch system	•	•	–	–	–
Adjustable film tension ( <i>from control panel</i> )	•	–	•	–	–
Smooth start / stop	•	•	•	•	•
Independent setting of rotation and carriage speeds	•	•	•	•	•
Lockable control panel	•	•	•	•	•
Top-sheet function	•	•	•	•	•
No. of top and bottom windings ( <i>independently settable</i> )	•	•	•	•	•
Automatic height detection	•	•	•	•	•
Top edge overlap ( <i>settable from control panel</i> )	•	•	•	•	•
Adjustable bottom overlap	•	•	•	•	•
Auto. film break detection	•	–	–	–	–
Pausable wrapping cycle	•	•	•	•	•

### OPTIONS & ACCESSORIES

- Photocell for dark or reflective surfaces
- Standard ramp: L = 1490mm
- Elongated ramp: L = 1870mm (for loading with pallet truck)
- Pit-frame for installation at ground level
- Film cutting punch (only on LP-carriage)
- Carriage for net-film
- Weighing system with control keyboard
- Low temperature version (-20°C)
- Stainless steel version

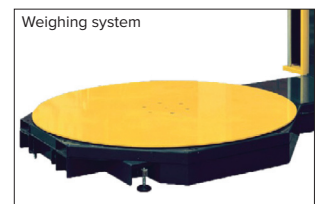
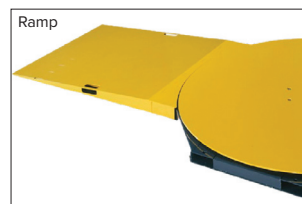
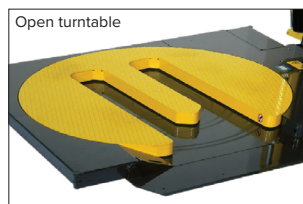
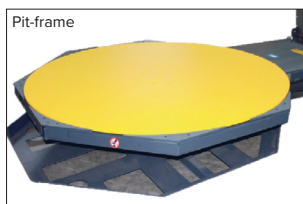

### FILM CARRIAGES

